

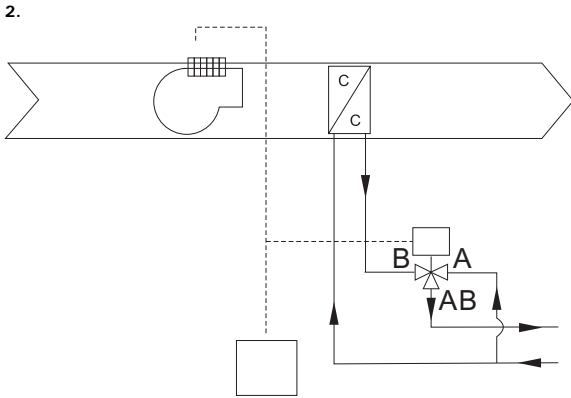

# MDV

CLIMATE SOLUTION FOR GREEN ENVIRONMENT

## TWVK-09

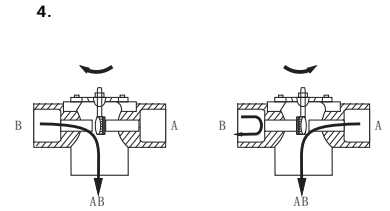
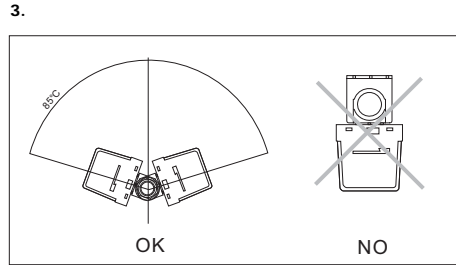
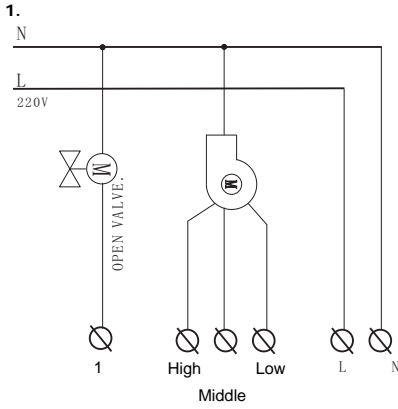

5.

220 / 50  
4  
1,6  
0-65

Kv=3.4  
Cv=4.0



Model	Dimensions (mm)			Kv	Cv = 1,1627 x Kv	Pressure (Mpa)
	87	37	96			
TWVK09	87	37	96	3.4	4.0	0.18Mpa